

*Vom selben Team, das auch **Kloster Dance 2016** produziert hat!*



Duisburg, im Februar 2017

Liebe Tänzer/innen!

Wir laden Euch recht herzlich ein zu unserem Tanzabend

Kloster Dance 2017

am 25. März 2017 um 19 Uhr
im evgl. Gemeindehaus

in Duisburg-Hamborn, Taubenstraße 14, 47166 Duisburg

**Neue
Location!**

Happy Dancing wünschen



The Swinging Kilts

Das Programm und alle anderen Details findet Ihr ab jetzt auch auf unserer Seite www.swinging-kilts.de. All denen, die in unserem Email-Verteiler sind, schicken wir es sowieso zu. (Schickt eine Mail an storkthomas@aol.com, wenn Ihr bisher noch nicht in unserem Verteiler seid.)

Wir probieren in diesem Jahr eine neue Location aus, nur etwa zwei Auto-Minuten vom letztjährigen Saal entfernt :

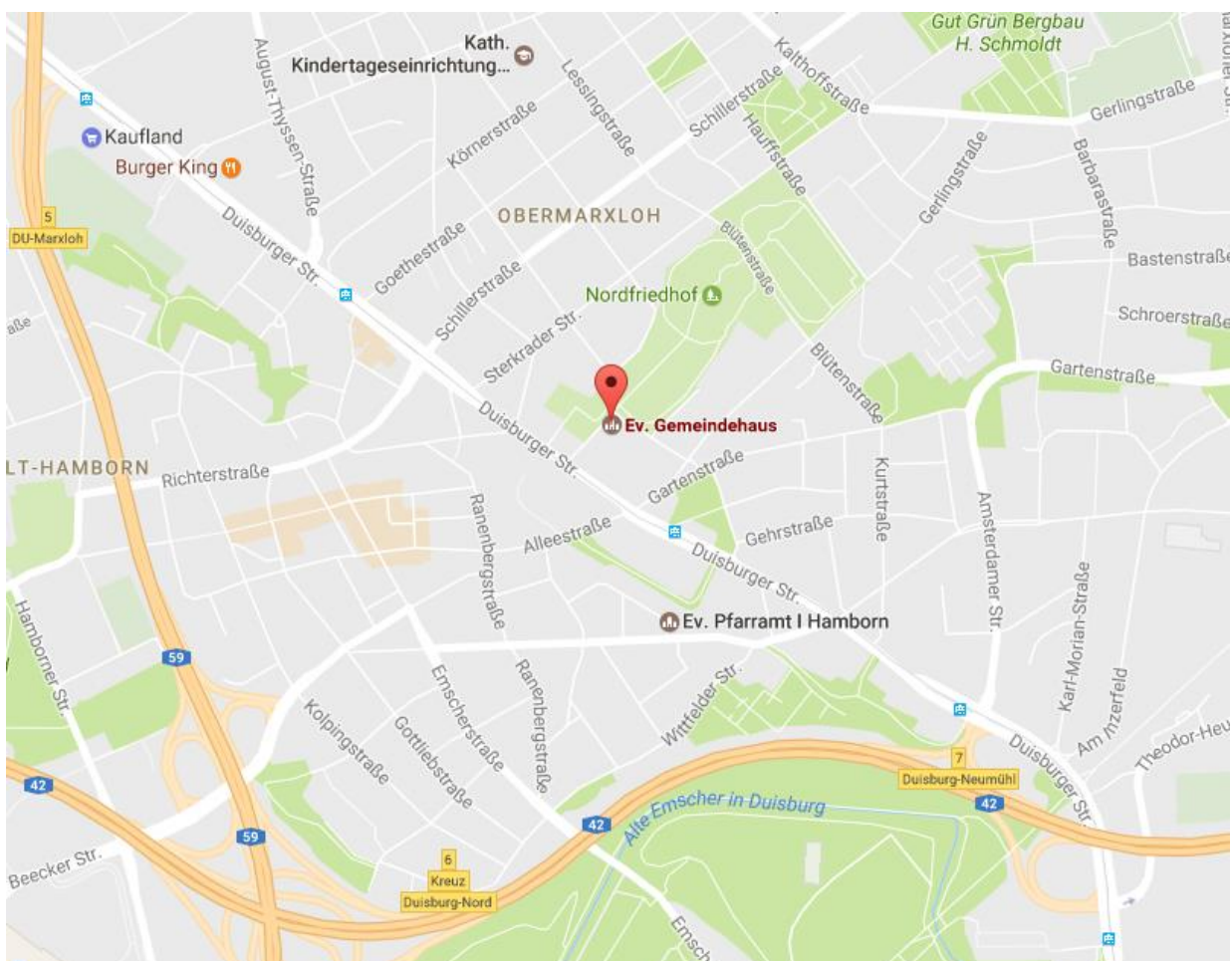

(Ein besseres Bild und eine Wegbeschreibung findet Ihr auf unserer Webseite.)

Programm

Trip to Gretna Green (J 8x32) (*Deviser unknown; dance has never been published*)

Swiss Lassie (R8x32) 3C (4C set) Rosi Betsche RSCDS Book 39

Two's Company, Three's a Crowd (S3x32) 3C set H Sherman

Les Remparts de Séville (J8x32) 3C (4C set) Aliénor Latour RSCDS Bk 50

Shiftin' Bobbins (R8x32) 3C (4C set) Roy Clowes Ormskirk 6

Asilomar Romantic (S8x32) 3C (4C set) Tom Cuthbertson San Fransisco Collection 2

Crom Allt (R8x32) 3C (4C set) Roy Goldring 24 G and S dances

Muirland Willie (J8x32) 3C (4C set) RSCDS Book 21

Cape Town Wedding (S8x32) 3C (4C set) Tom Kerr RSCDS Book 39

Da Rain Dancin' (R8x32) 3C (4C set) Ron Wallace Whiteadder Collection

Mist o'er the Loch (S8x32) 3C (4C set) Mervyn C Short Queen's Diamond Jubilee

Dancing Spirit (J8x32) 3C (4C set) Amy Luxton RSCDS Bk 50

Twelvesome Reel (R6x32) 6C Sq.Set Barry Priddey Twelvesome Reel and Four More SCD

Postie's Jig (J4x32) 4C set Roy Clowes Ormskirk 5

Klosterdance Jubilee (M64/64) Sq set Duisburg Collection

The Deil Amang the Tailors (R8x32) 3C (4C set) RSCDS Book 14

Christine M Phillips (J8x32) 3C (4C set) John Brenchley RSCDS Book 46

Sugar Candie (S8x32) 3C (4C set) RSCDS Book 26

Extra: The Bees of Maggieknockater (J4x32) 4C set John Drewry Canadian Book

Klosterdance 2017 am 25. März 2017 um 19 Uhr

Evangelisches Gemeindehaus, Taubenstraße 14, 47166 Duisburg, Duisburg-Hamborn

Trip to Gretna Green

3C/4C longwise set (J8x32)

- 1- 1c cross RH | cast (2c up) ; 2c+1c+3c A&R
- 9- 1c cross LH and cast L into lines across ; 2c+1W & 1M+3c A&R
- 17- Reels3 across 1c giving Rsh to 1cnr, finish BtB facing 1cnr
- 25- 1c turn 1cnr RH | pass P Rsh ; turn 2cnr RH, pass P Rsh to (2,1,3)

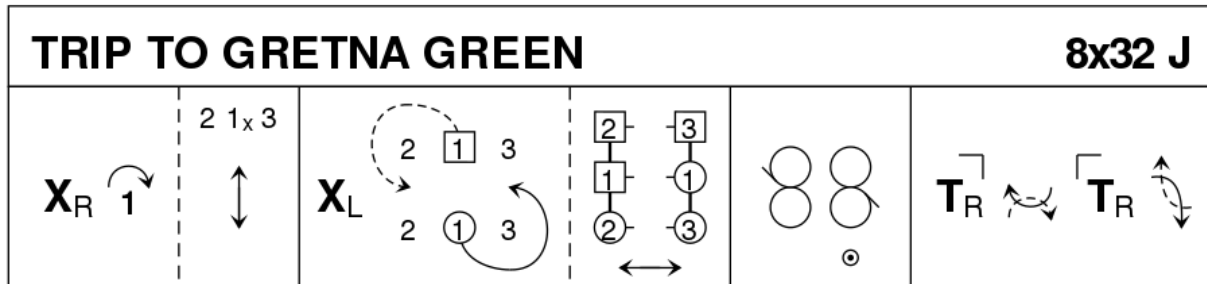

3C/4C longwise set

Swiss Lassie

3C/4C longwise set (R8x32)

- 1-8 1s dance in & cast to 3rd place, 2s+1s turn partners RH 1.1/4 times to form a line up & down middle of set (Men facing down Ladies up)
- 9-16 2s+1s dance reel of 4 up & down middle of set ending with 2M facing Ladies side & 1L facing Men's side
- 17-24 2s+1s chase round clockwise 1/2 way, 1s+3s+2s Adv+Ret
- 25-32 3s+2s 1/2 turn partners RH, dance RH across 1/2 way, 1s+2s 1/2 turn partners RH & dance RH across 1/2 way

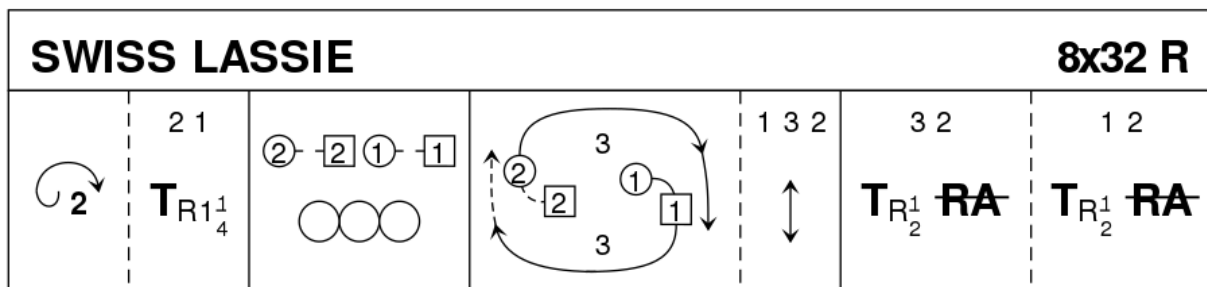

Rosi Betsche, RSCDS Book 39.1

3C/4C longwise set.

Two's Company, Three's a Crowd

3C/3C longwise set (S6x32)

- 1-8 1s+2s+3s set & dance La Baratte:
- 2-4 Men 1/2 turn opposite Lady RH & retains hand but at arm's length from each other
- 5-6 Men retrace steps with Lady turning right under Man's arm briefly into Allemande hold (Man behind Lady facing Ladies original place) & releasing Ladies RH she turns under Mans left arm until almost in original places
- 7-8 Couple change places LH to opposite places
- 9-16 1s+2s+3s Set+Link for 3 twice to end 3 2 1
- 17-20 3s+2s Set+Link
- 21-32 All dance 3 couple R&L. 2 3 1

Two's Company, Three's a Crowd		6x32 S	
1 2 3 — 1 2 3 — S La Baratte	1x 2x 3x Set & Link for Three R	3 2 Set & Link for Two Three Couple R&L R R	

Les Remparts de Seville

3C/4C longwise set (J8x32)

- 1-8 1s set, cast (2s step up bars 3-4), 1s dance 1/2 Figs 8, 1L round 2s, 1M round 3s
- 9-16 1s turn LH to face 1st corners & dance set to corners & partner ('Hello-Goodbye') to end 1M between 2s facing down, 1L between 3s facing up
- 17-24 2s+1s+3s Set+Link, all set, all cross RH
- 25-32 2s+1s+3s circle 6H round & back

LES REMPARTS DE SÉVILLE				8x32 J	
S		1x T_L S	1x S S		2x 1x 3x S X_R
					6

Shiftin Bobbins

3C/4C longwise set (R8x32)

- 1-8 1s cross RH to double triangle position with 2s+3s & set, 1s cast up to top & dance down until they are between 2s & 3s
- 9-16 1L dances RH across with 2M+3M **while** 1M dances LH across with 2L+3L, 1s followed by 2s+3s dance down centre
- 17-24 3s followed by 2s+1s dance up & 3s+2s cast down to places, 1L dances LH across with 2M+3M **while** 1M dances RH across with 2L+3L
- 25-32 1s dance up to top & cast down to 2nd place opposite side, 1s dance 1/2 Fig of 8 around 2s to end in 2nd place on own sides

SHIFTIN' BOBBINS				8x32 R	

Asilomar Romantic

3C/4C longwise set (S8x32)

- 1-8 1s+3s dance double Fig of 8 around 2s, 1s crossing down to start
- 9-16 1s+2s dance Diamond Poussette
- 17-24 1s dance in & down between 2s (2s step up), set to each other & dance RSh round 4th corner to face own 1st corner
- 25-32 1s dance 'Hello-Goodbye' setting ending with petronella turn to 2nd places

ASILOMAR ROMANTIC			8x32 S	
 Double Figure of 8	1 2 P	\xrightarrow{N} S		S S S T _◇

Crom Allt

3C/4C longwise set (R8x32)

- 1-8 1s dance reels of 3 on own sides (in & down to start)
 9-16 1s+2s turn on sides 1.1/2 times (Men RH & Ladies LH), 1s dance between 3s & cast up to 2nd place on own sides
 17-24 1s+1st corners Adv+Ret, 1s+1st corners turn RH
 25-32 1s+2nd corners Adv+Ret, 1s+2nd corners turn LH

CROM ALLT			The Crooked Burn		8x32 R	
	 T _{L1¹₂ T_{R1¹₂}}			T _R		T _L

Muirland Willie

3C/4C longwise set (J8x32)

- 1-4 1s lead down middle & cross over to cast up to 2nd pl **while** 2s set & cross RH to 3rd pl **while** 3s cast up to 1st place & cross RH
 5-8 All set & 1/2 turn 2H to own side
 9-16 Repeat bars 1- 8 from new pstns
 17-24 1s lead up to 1st place & set, 1s+2s set advancing
 25-32 1s+2s dance Poussette. 2 1 3

MUIRLAND WILLIE				8x32 J			
 X _R	 S _R	 X _R	S T _{B¹₂}	R		S S _↑	P

Cape Town Wedding

3C/4C longwise set (S8x32)

- 1-8 1s cross (no hands) to 2nd place, dance out & 1/2 turn 3s with nearer hand, 1s (in 3rd pl) 1/2 turn RH & lead up to top ending in prom hold
 9-16 1s in prom hold dance reel of 3 with 2s (RSh to 2L to start) 1s end in middle at top facing down (Lady on Mans Left) & 3s step in & face up
 17-24 1s+2s+3s set, 1s+3s Petronella-in-tandem to sides as 2s petronella into middle, 1s+2s+3s (join hands in circle) set & cast back to places
 25-32 1s+2s dance the Knot

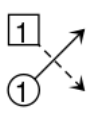
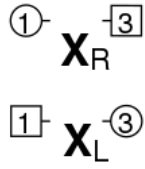
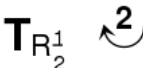
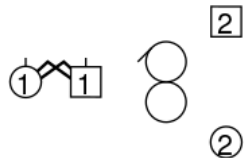
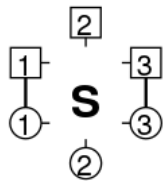
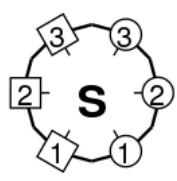
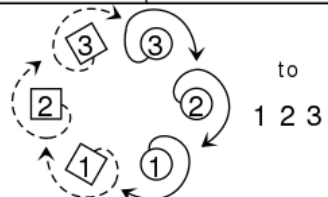
CAPE TOWN WEDDING		8x32 S	
	 X_R X_L	 $T_{R_2}^1$	
 S	ALL T_{\diamond}	 S	 to 1 2 3
			1 2 KNOT





DA RAIN DANCIN' (R8x32) 3C (4C set) Ron Wallace Whiteadder Collection

1- 8 1s dance down below 3s, cast up round 3s to 2nd place own side, 2s+1s+3s set and cross RH

9-16 1s dance up round 2s and cast down to 2nd place opposite sides, 2s+1s+3s set, 1s turn LH to face 1st corners while 2s and 3s cross LH

17-24 1s dance 'Hello-Goodbye' setting with 1st corners and $\frac{3}{4}$ turn RH to face 2nd corners, 1s dance 'Hello-Goodbye' setting to 2nd corners and $\frac{3}{4}$ turn RH to end 2nd place own side

25-32 2s+1s+3s circle 6H round and back

DA RAIN DANCIN'		8x32 R	
 N	 1	$2\ 1\ 3$ $S\ X_R$	$2x\ 1x\ 3x$ S
		 N	 1
		$2x\ 3x\ 1x$ $X_L\ T_L$	
S^{\lrcorner}	$2\ \textcircled{1}\ 3$ $T_{R_4}^3$ $2\ \textcircled{1}\ 3$	S^{\lrcorner}	$2\ 3$ $\textcircled{1}\ T_{R_4}^3\ \textcircled{1}$ $2\ 3$
		$2\ 1\ 3$ $\textcircled{6}$	

Ron Wallace, 1991, Whiteadder Collection

3C/4C longwise set.

Mist over the Loch

3C/4C longwise set (S8x32)

1-8 1s+2s set & circle Left $\frac{1}{2}$ way, 2s+1s turn 2H $1\frac{1}{2}$ times 2 1 3

9-16 1s dance $\frac{1}{2}$ figure of 8, (1M with 2s, 1L with 3s) to end 2nd place opposite side, 1s dance $\frac{1}{2}$ diag R&L (1L up, 1M down)

17-20 1s dance $\frac{1}{2}$ Fig of 8 (1M down, 1L up) & end 2nd place opposite side

21-24 1s dance $\frac{1}{2}$ diag R&L (1M up, 1L down) 1s end passing LSH to face 1st corner (pstns)

25-28 1s dance Pass+Turn with 1st corners (corners turn 2H & twirl to end in each others places) & 1s pass RSh to face 2nd corner (pstns)

29-32 1s repeat with 2nd corner (pstns) then 1s pass RSh to 2nd place own side 2 1 3

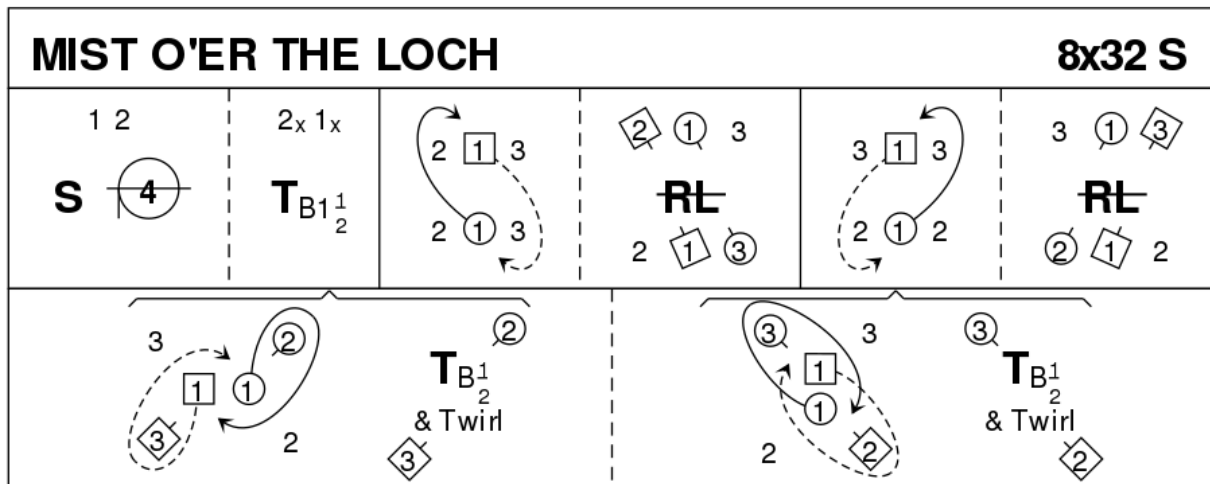

Mervyn C Short, RSCDS QE Diamond Jubilee

3C/4C longwise set.

Dancing Spirit

3C/4C longwise set (J8x32)

- 1-8** 1s turn RH moving down to face 3rd corners (2s step up 1-2). 1s+3rd corners (2M+1s+3L) dance 1/2 reel of 4. 1s pass LSh to face 4th corners
- 9-12** 1s+4th corners (2L+1s+3M) dance 1/2 reel of 4. 1M curves in to face 2L as 1L curves in to face 3M
- 13-16** 1s dance RSh round corner & join RH, joining LH with corner to Bal-in-Line position
- 17-24** 1s+2s+3s dance 'The Spoke'. Bars 23-24 1s retain RH, turn to 2nd place opp sides (skip change) **while** 3s+2s set. (3) (1) (2)
- 25-32** 3s+1s+2s dance clockwise 1/2 round then turn partners RH once round

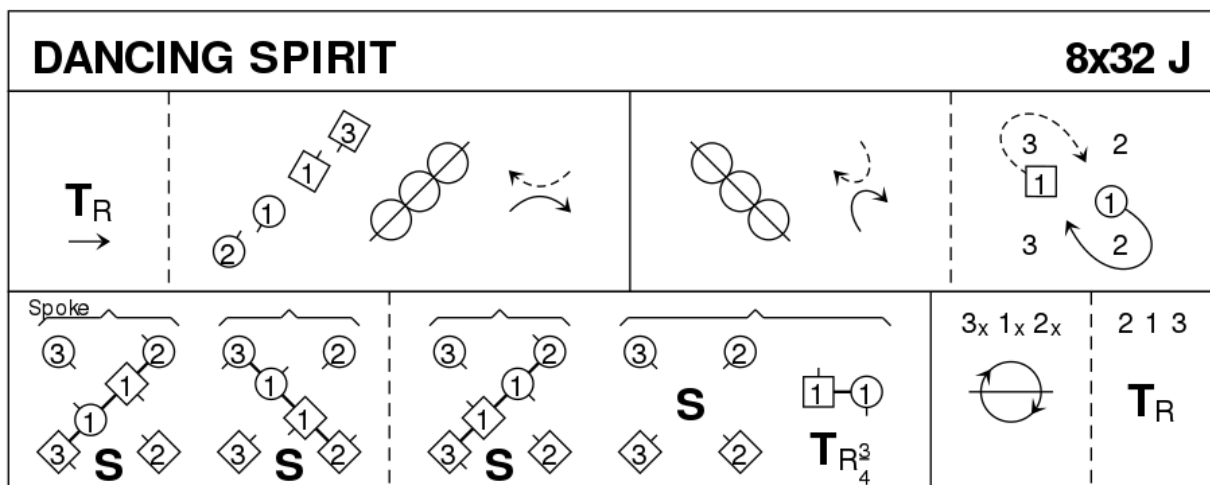

Amy Luxton, 2014, RSCDS Book 50.11



3C/4C longwise set.

Twelvesome Reel

6C square set (R6x32)

6 couples: couples 1, 2, 3 & 4 make square set, couples 5s & 6s in middle, 5s facing 1s, 6s facing 3s

- 1-8** 1s+2s+3s+4s circle 8H left 1/2 way, set adv, turn right & dance out (to new places) **while** 5s+6s set to ptnr, set facing diagonally in to centre & dance LH across
- 9-16** 3s+5s+6s+1s dance parallel reels of 4, 3s & 1s ending in place & 5s+6s omit LSh pass to end facing 2s & 4s
- 17-24** 4s+5s+6s+2s dance parallel reels of 4, 4s & 2s ending in places & 5s+6s omit LSh ready for...
- 25-32** 5s & 6s dance RH across with corners (in threes), 5s+6s dance LH across in centre **while** 1s+2s+3s+4s circle 1/4 round to left, 2s+5s also 4s+6s RH across 1/2 way (to put new couples - 2s & 4s - in centre) **while** 1s & 3s turn partners RH

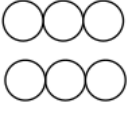
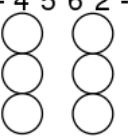
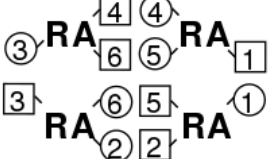
TWELVESOME REEL			6x32 R
2 2 1 5 6 3 1 5 6 3 4 4	1 2 3 4 --- 5 6 ---  S S diag. opposite	-- 1 2 3 4 -- -- 5 6 -- S  LA cast back to place	--- 3 5 6 1 ---  5c+6c omit last pass
--- 4 5 6 2 ---  5c, 6c omit last pass	 CHASE LA one place clk.	3 4 1 2 6 5 3 1 2 5 6 4 T_R RA RA	



Barry Priddey, Twelvesome Reel and 4 more

6C square set

Postie's Jig

4C/4C longwise set (J4x32)

- 1-8 1s & 4s set & cast in 1 place, 1s & 4s dance 1/2 Figs of 8 round new end couples
- 9-12 1M+4M & 1L+4L cross (men making an arch) & turn corners with free hand to face up/down
- 13-16 1s+4s dance down/up (couple dancing up make the arch) & turn corners
- 17-24 Repeat bars 9-16 from new pstns
- 25-32 1s+4s dance 1/2 R&L, turn partner RH

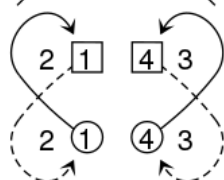
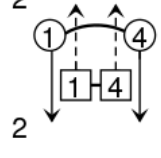
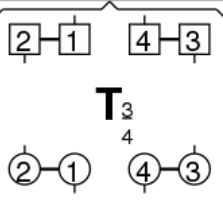
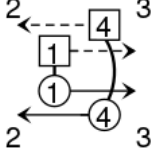
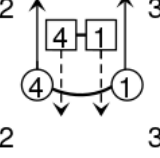
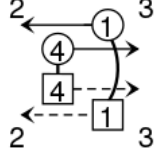
POSTIE'S JIG			4x32 J
1 4 1 4 S  		2 3 	 T₃ 4
 ALL T₃ 4	 ALL T₃ 4	 ALL T₃ 4	1 x 4x RL T_R

Roy Clowes, Ormskirk 5

4C/4C longwise set.

Klosterdance Jubilee

4C/4C longwise set & square set (M:S64+R64)

Strathspey in 4c longwise set

- 1- 4 1s followed by 2s, 3s and 4s cast down (to 4 3 2 1)
- 5- 8 all Set and cross RH
- 9-12 1s followed by 2s, 3s and 4s cast up back to 1 2 3 4
- 13- 16 all Set and cross RH
- 17-20 1s & 4s lead down/up (2s & 3s step up/down) and dance half RA
- 21-24 1s&4s lead up/down, cross and cast around corners (to 2 4 1 3)
- 25-28 2s&4s and 1s&3s dance RA
- 29-32 2s&4s and 1s&3s dance LA
- 33-60 Repeat 1-28 from new places
- 61-62 2s&3s cast and chase clockwise for 1 pl
- 63-64 All turn RH into square set (2s and 4s half turn, 1s and 3s full turn) (to 4 3 1 2 from top & clockwise)

Reel in square set

- 1- 4 All circle to the left 1/2 way round
- 5- 8 All set and spring point (Highland steps)
- 9-16 Double Ladies' Chain
- 17-20 All set, Ladies cast into partner's place WHILE Men pass into Ladies' place of the couple to the right (turn over right shoulder at the end to face in)
- 21-24 All repeat bars 17-20, but Men cast and Ladies dance to the right
- 25-32 All repeat bars 17-24
- 33-36 All circle to the right 1/2 way round
- 37-40 All set and spring point (Highland steps)
- 41-48 Double Men's Chain
- 49-64 All repeat bars 17-32

Strathspeur

	<p>All S X_R</p>
	<p>All S X_R</p>
	<p>RA LA</p>
<p>Repeat 1-24</p>	<p>All T_R to 2 4 3 1</p>

Reel

	<p>All S + spring point</p>	<p>Double Ladies' Chain</p>
<p>All</p>	<p>All</p>	<p>Repeat 17-24</p>
	<p>All S + spring point</p>	<p>Double Men's Chain</p>
		<p>Repeat 17-32</p>

The Deil Among the Tailors

3C/4C longwise set (R8x32)

- 1-8 1s+2s set & dance RH across 1/2 way, set & dance LH across 1/2 way back to place
- 9-16 1s lead down the middle & back to top
- 17-24 1s+2s dance Allemande
- 25-32 2s+1s+3s circle 6H round & back

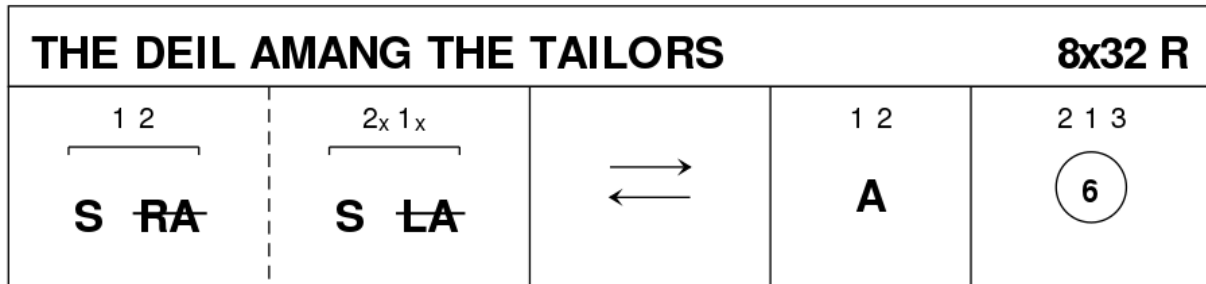

Davies Collection, RSCDS Book 14.7

3C/4C longwise set.

Christine M Phillips

3C/4C longwise set (J8x32)

- 1-8 1s set advancing & lead down below 3s crossing 1s cast to 2nd place opp sides & turn LH to face 1st corners
- 9-16 1s dance 1/2 reel of 4 with 1st corners, 1s turn 3rd corners (pstn) RH & turn LH to face 2nd corners
- 17-24 1s dance 1/2 reel of 4 with 2nd corners, 1s turn 4th corners (pstn) RH & turn LH to Man facing up Lady down
- 25-32 1M+3s (at top) also 1L+2s dance RH across, 1s turn LH to 2nd place own sides **while** 2s+3s chase 1/2 way clockwise

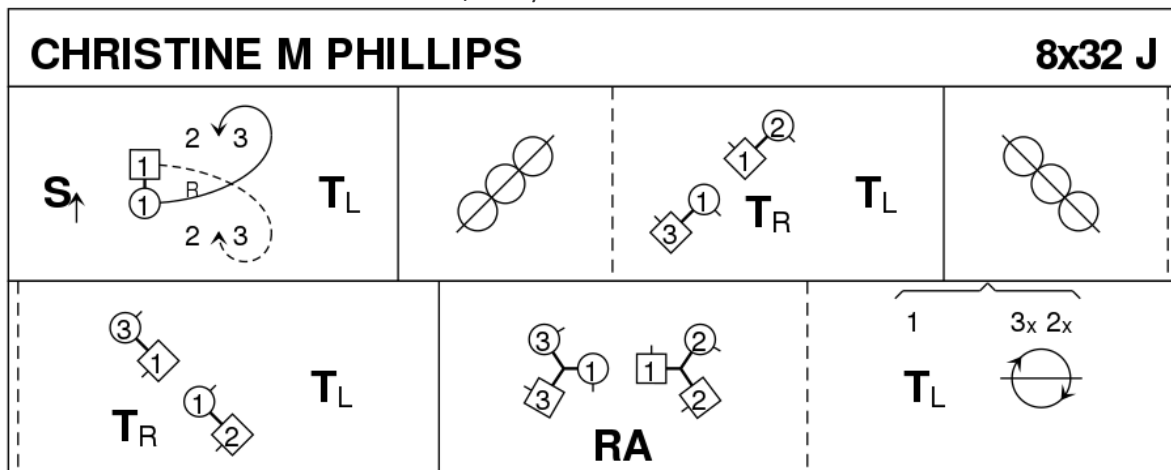

Sugar Candie

3C/4C longwise set (S8x32)

- 1-8 1s set & cast 1 place, cross passing LSh & cast RSh round their 1st corner into centre ending BtoB (Lady facing up, Man down)
- 9-16 1L circle left with 2s & 1M with 3s, turn to face partner & set, 3/4 turn partner 2H to end facing 1st corners
- 17-24 1s turn 1st corner RH, partner LH, 2nd corner RH, partner LH & end facing 1st corners
- 25-32 1s dance Reel of 3 on opposite sides passing 1st corner LSh & cross RH to 2nd

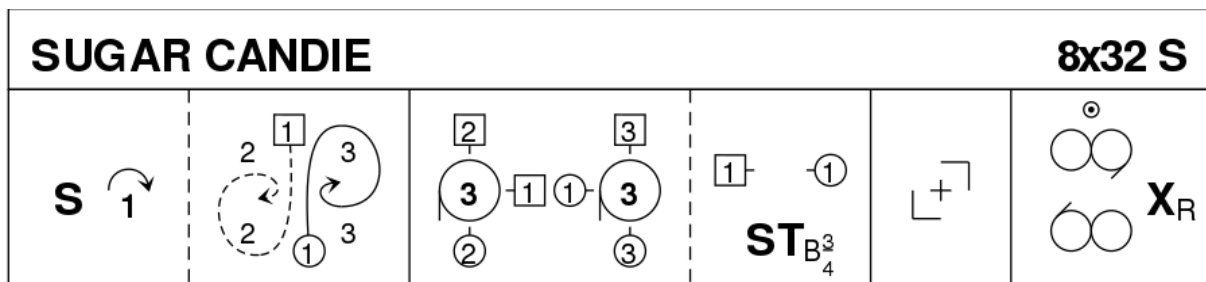

The Bees of Maggie Knockater

4C/4C longwise set (J4x32)

- 1-8 1s cross RH & cast 1 place, dance RH across with 3s & end 1M+3L also 1L+3M in prom hold facing out to pass corner person RSh
- 9-24 All dance 4x1/2 Reels of 3 on sides (to right to start, then left, right & left) with 1s+3s changing partners in centre at end of each 1/2 Reel to progress Men clockwise & Ladies anticlockwise. End in centre 1s facing down & 3s facing up
- 25-32 1s dance between 3s turning 3s with nearer hand 1.1/2 times, crossing over to own sides & turn 4th person 1.1/2 times (Men RH & Ladies LH)

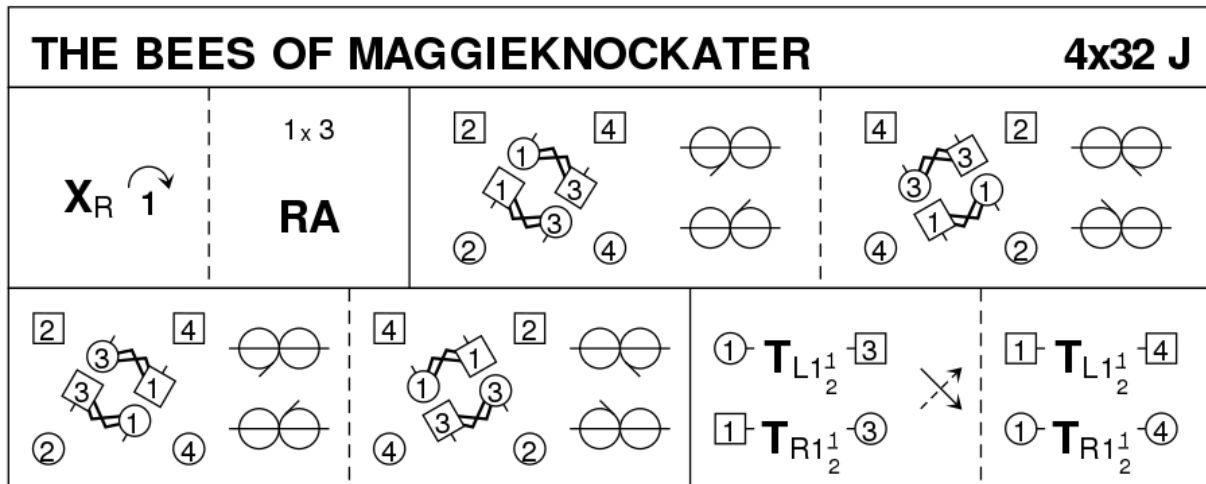

John Drewry, 1975, Canadian Book

4C/4C longwise set.