

TRIP TO TIMBER RIDGE (R8X32) 3C (4C set) Linda Henderson Heart, RSCDS Book 52

- 1- 8 1s turn RH, cast (2s step up) then 1L+2s and 1M+3s dance RH across. 1s end facing 1st corners
- 9-16 1s dance Corner Pass&Turn with 1st corners, pass RSh and repeat with 2nd corners. 1s pull back RSh to end BtoB in centre facing opposite sides
- 17-24 2s+1s+3s dance Double Triangles. Bars 23-24 1s petronella turn to 2nd place own sides
- 25-32 2s+1s+3s circle 6H round and back

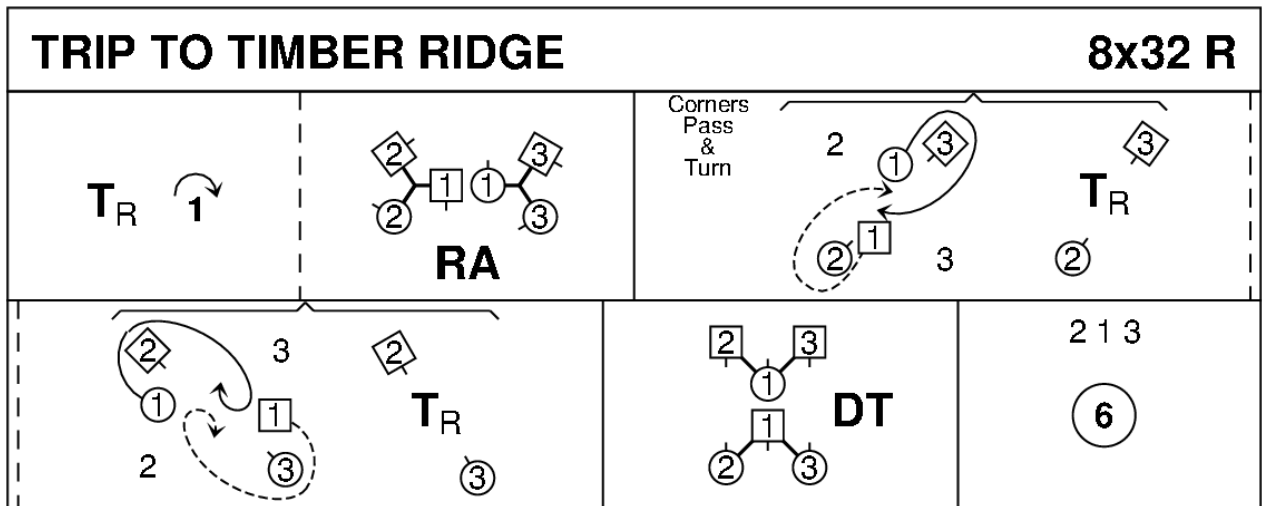

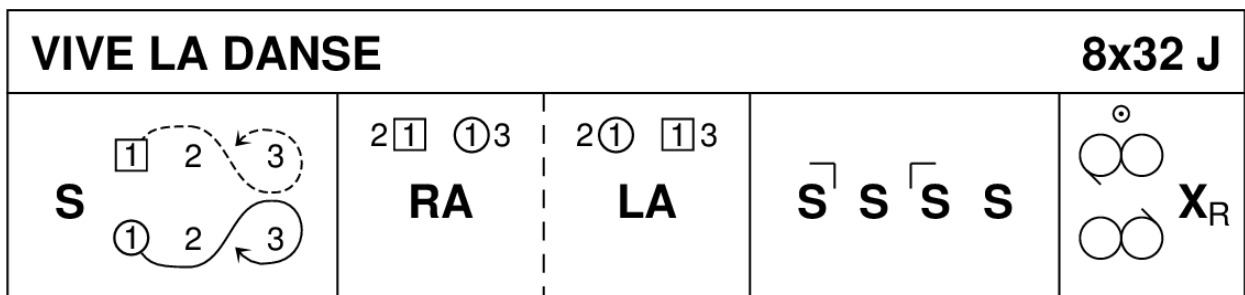

VIVE LA DANSE (J8x32) Ann Dix, Reel Friends 3

- 1- 8 1s set, cast 1 place, dance down between 3s and cast up 1 place to end in middle LSh to LSh
- 9-16 1s dance RH across (Lady with 2s and Man with 3s), pass RSh to dance LH across with other couple and end passing LSh to face 1st corners
- 17-24 1s dance 'Hello-Goodbye' setting and end BtoB (Man facing up)
- 25-32 1s dance reels of 3 on opposite sides giving RSh to 2nd corners and cross RH to 2nd places



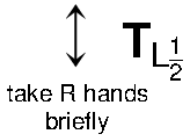
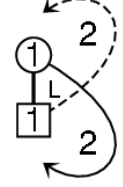
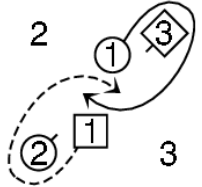
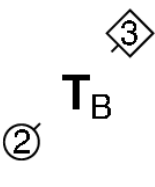
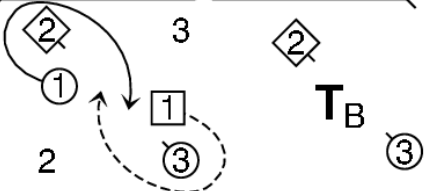

TRIPLE HAPPINESS (S3x32) Yoshiki Oyama, Book 52

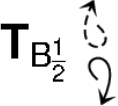
- 1- 8 1s Adv&Ret (1 step each) touching hands, 1s ½ turn LH, cross down between 2s and 3s, cast up to place
- 9-16 1s+2s dance the Knot. 1s end facing 1st corners
- 17-24 Corners Pass&Turn with 1st corners, Repeat with 2nd corner and 1s pass RSh into 2nd place own sides (corners turn 2H in centre) 213
- 25-32 All chase clockwise ½ round to opposite sides, all ½ turn 2H, pull back RSh and dance out to own sides. 312

TRIPLE HAPPINESS			3x32 S	
 <p>↑ ↓ T_L^{1/2} take R hands briefly</p>		1 2 KNOT	 <p>Corners Pass & Turn</p>	 <p>T_B</p>
 <p>T_B</p>		2 1 3 	3x 1x 2x  <p>T_B^{1/2}</p>	

BLUE BONNETS (J8x32), Book 3

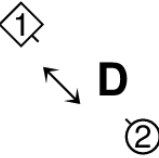
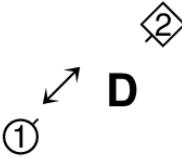
- 1- 8 1L+2M Adv&Ret and dance DoSiDo
- 9-16 1M+2L Adv&Ret and dance DoSiDo
- 17-24 1s lead down the middle and back
- 25-32 1s+2s dance Poussette. 2 1

BLUE BONNETS		2 couples	8x32 J
 <p>D</p>	 <p>D</p>		1 2 P

THE BON VIVEUR (M-(S2x32+R2x32)) Sq.Set, I and C Brockbank, Bk 52



1- 8 All circle 8H round and back

9-16 1s+3s dance Men's Chain finish with Ladies facing out

17-28 All dance Schiehallion reels (12 bars) to finish 1 place clockwise from starting place. 4123

29-32 All birl (or turn) partners RH. 4123

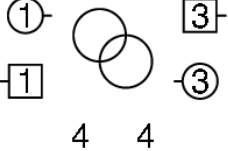
Note: Dance twice as Strathspey, twice as Reel

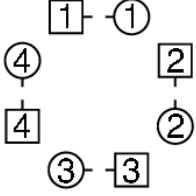
THE BON VIVEUR		2x32 S + 2x32 R	
	<p>2 2</p> 	<p>Schiehallion Reel</p>  <p>12 bars</p>	<p>ALL</p>  <p>T_R Birl</p>

THE ULLAPOOL FERRY (R4x32) Pat Houghton, Book 52

1- 8 1s+2s dance Double Fig of 8 (1s cross down, 2s dance up). 2s end facing out

9-12 ½ mirror reels of 3 on sides (1s in/down to start). 2s face out

13-16 1s turn RH while 2s+3s turn 1½ on sides (Ladies LH, Men RH) 2314

17-24 1s+4s set, dance DoSiDo; 1M and 4L set on sides while partners set advancing to face partner on diagonal



25-32 1s+4s dance "Hello-Goodbye Poussette":-

' 25-26 All set moving on 2nd step into lines across (1M+4L BtoB)

' 27-28 Repeat, moving on 2nd step into diagonal lines between 3L and 4M place (1L+4M BtoB)

' 29-30 Repeat, moving on 2nd step into line up/down (4L+1M BtoB)

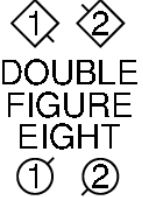
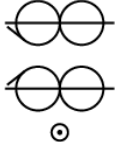
' 31-32 4s+1s drop hands and petronella turn to sides. 2341

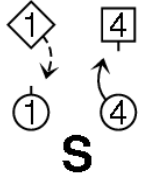
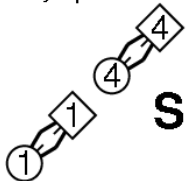
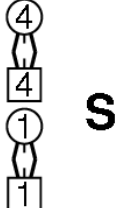
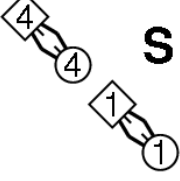
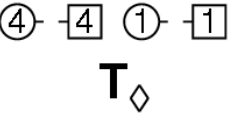
THE ULLAPOOL FERRY		4x32 R	
 <p>DOUBLE FIGURE EIGHT</p>	<p>1 2 3</p> 	<p>T_L 1½  T_R</p> <p>T_R 1½  T_R</p>	<p>1 4</p> <p>S D</p>  <p>S</p>
<p>Hello-goodbye poussette</p>  <p>S</p>	 <p>S</p>	 <p>S</p>	 <p>T_◇</p>

CITY LIGHTS (J8x32) Nicola Scott; Bk 52

- 1- 8 1s turn RH, cast (2s step up), turn $1\frac{1}{4}$ LH to face 1st corners
- 9-12 Corners Pass and Allemande Turn:-
 ' As Corners Pass&Turn, corners dance in, join RH, Lady dances under Man's arm. Lady curves out to place as Man retires.
- 13-16 1s in centre turn $1\frac{1}{4}$ LH to face 2nd corner positions while corners chase clockwise $\frac{1}{2}$ round
- 17-24 Repeat 9-16 with 2nd corner positions. 1s end in centre LSh to LSh facing opposite sides
- 25-32 1L+2s and 1M+3s dance RH across; all turn partners RH (or birl) 213

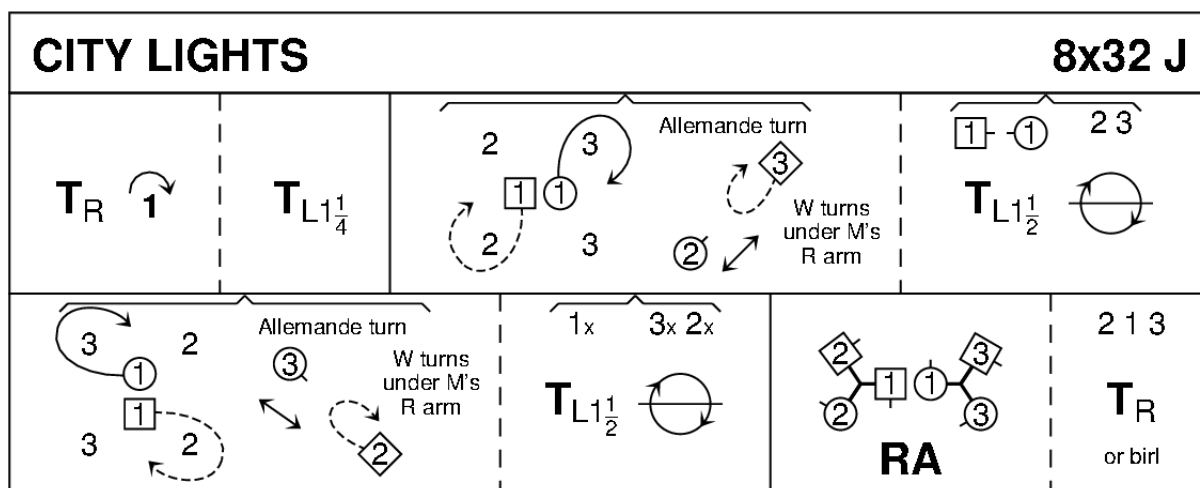

SLYTHERIN HOUSE (S8x32) 3C (4C set) Chris Ronald; Book 52

- 1- 8 1s+2s Set+Link; circle 4H round to Left. 213
- 9-16 1s pull back RSh, cast round 3rd corner (Man up/Lady down), pass LSh in centre and dance LSh round 1st crnr (6 bars) 1s turn $\frac{3}{4}$ LH to end in centre 1M below 1L, facing opp sides
- 17-20 1L+2s and 1M+3s dance RH across
- 21-24 "Snake Pass":-
 ' 1L followed by 2L and 2M, 1M followed by 3M and 3L, pass LSh in the middle, dance out to the side, down to 3rd/up to 1st place, cross to own side and cast up/down to 2nd place in middle, RSh to RSh facing opposite sides
- 25-28 1M+3s (at top) and 1L+2s (at bottom) dance LH across
- 29-32 Repeat "Snake Pass" with dancers passing RSh in middle and all finish on sides. 213

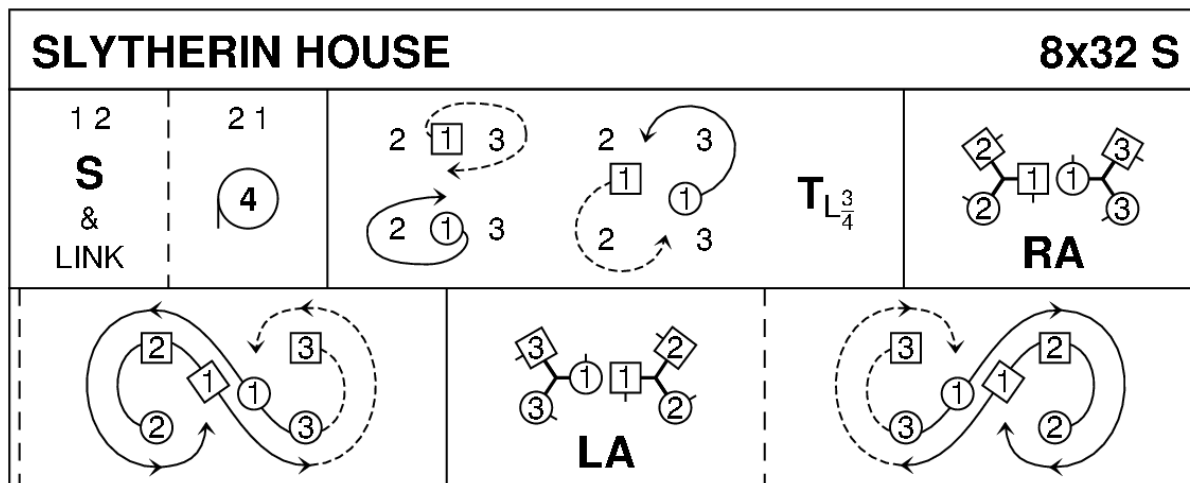

FLOWERS OF EDINBURGH (R8x32) Book 1

- 1- 8 1L followed by partner casts below 3s, 1L crosses and dances up behind Men as 1M dances up centre to 1st places on opposite side and 1s set
- 9-16 1M followed by partner repeat above Fig and set in own places
- 17-24 1s lead down the middle and back
- 25-32 1s+2s dance Poussette. 213

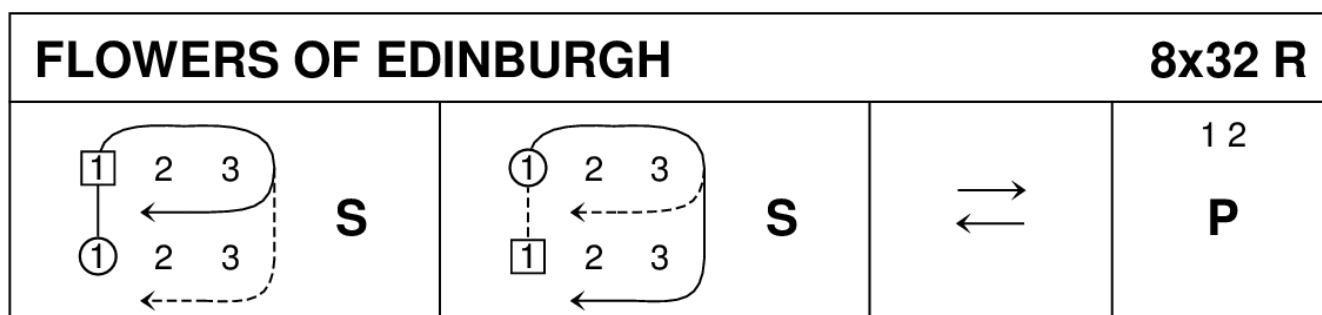

THE EIFEL WELCOME (S8x32) Rudolf Spägele

- 1- 8 1s cross RH and cast 1 place, cross RH and cast right (1M ends between 2s, 1L ends between 3s)
- 9-12 1s in lines of 3 Adv&Ret (for 1 up/down) and change places RH
- 13-16 All repeat bars 9-12
- 17-24 1s cross RH and cast to 2nd place own side, 1s turn RH
- 25-32 2s+1s+3s circle 6H round and back

THE EIFEL WELCOME

8x32 S

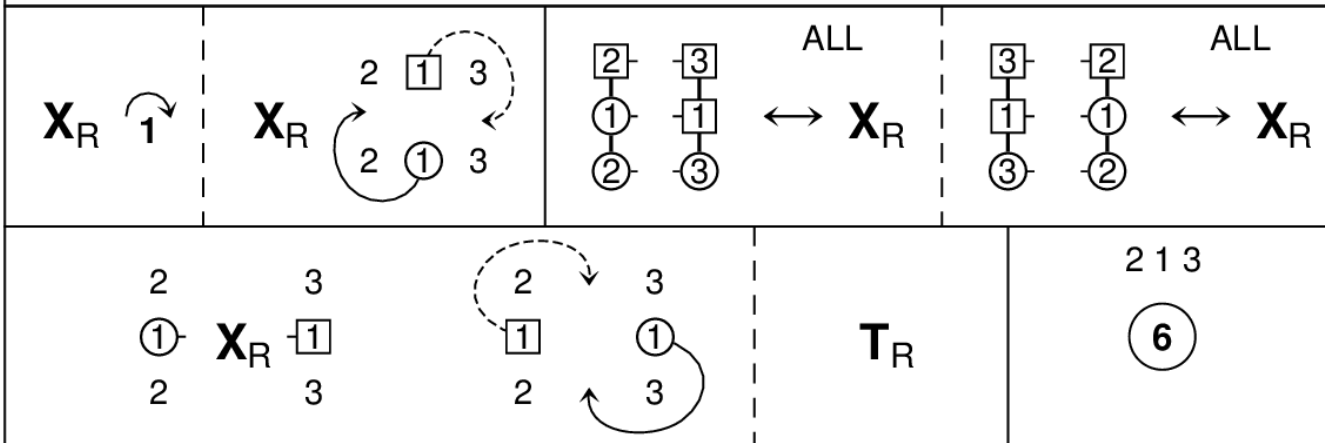

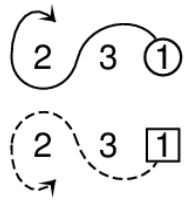
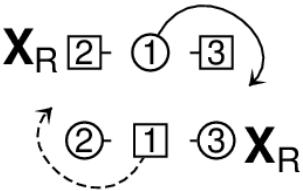
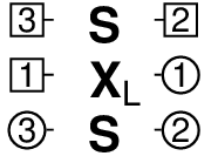
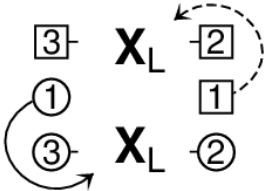

14/12 (R8x32) Alan Paterson, Collecta Ursis

- 1- 8 1s+2s+3s petronella turn and set, $\frac{3}{4}$ turn RH and set (all on opposite sides)
- 9-16 1s+2s set and dance $\frac{1}{2}$ RH across, 1s+3s set and dance $\frac{1}{2}$ RH across
- 17-24 1s cast up 1 place and dance to top, cast to 2nd place opposite sides and set turning to face out
- 25-32 1s cast to right and cross up/down, cast to 2nd place own sides while 2s+3s change places RH on sides and set up/down then change back RH, all set

14/12				8x32 R
1 2 3 T \diamond S	1 2 3 T $R_{\frac{3}{4}}$ S	1x 2x S RA	1 3x S RA	 S \curvearrowright
 X _R \square ① \square ③ ② \square ① \square ③ X _R	 S \square ② X _L \square ① S \square ②	 X _L \square ② X _L \square ① X _L \square ②	2 1 3 S	

IT'S JUST FOR FUN (J8x32) Roy Fidler, Book 33

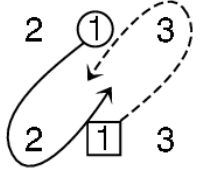
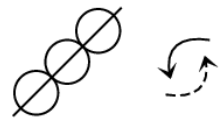
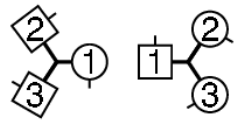
- 1- 8 1s cross RH and cast 1 place, 1M dances $\frac{1}{2}$ Fig of 8 round 2s while 1L dances round 3s 1s end facing 1st corners
- 9-16 1s dance $\frac{1}{2}$ reel of 4 with 1st corners, pass LSh and dance RH across (1M with couple in 1st place and 1L with couple in 3rd place) 1s end facing 2nd corners
- 17-24 1s dance $\frac{1}{2}$ Reel of 4 with 2nd corners, pass partner LSh to dance RH across (1M with 2L+3L on Men's side and 1L with 2M+3M)
- 25-32 1s $\frac{1}{2}$ turn LH while 2s+3s change places RH on sides, 1M dances up and 1L down, cast on own sides while corners set and cross RH and all set

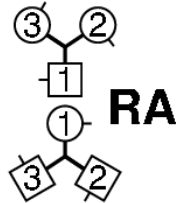
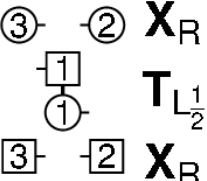
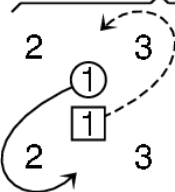
IT'S JUST FOR FUN				8x32 J
X _R \curvearrowright ①			 RA	
	 RA	 X _R \square ② T _L \square ① X _R \square ②	 S X _R S	

A TRIP TO BAVARIA (R4x32) James MacGregor-Brown, Guide To SCD (ex-Collins)

- 1- 4 1s and 4s cross RH while 2s+3s dance ½ RH across, 1s+3s and 2s+4s change places LH on sides
- 5- 16 Repeat 1-4 another 3 times (end couples cross RH, middle couples ½ RH across; couples in 1st+2nd place also 3rd+4th place change places LH) All finish in original places
- 17-24 1s set to 2s and cross over to face 3s, set and cross to face 4s
- 25-32 1s set to 4s and cross over to 4th place on opposite sides, all Adv&Ret 2 steps and 1s change places RH (2H popular) to retire to own sides. 2341

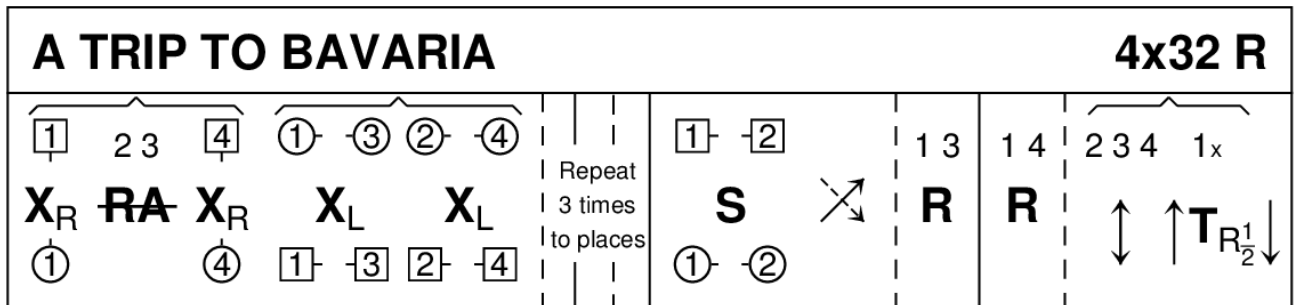

CULLA BAY (S4x32) Sq.Set Ann Dix, Book 41

- 1- 4 1s and 3s advance and ½ turn opposite partner RH and cast out to opposite side
- 5- 8 1s and 3s chase ¼ round set clockwise and dance in passing 2s/4s RSh curving in to face 2s/4s as 2s and 4s repeat bars 1-4 and turn right about to face 1s/3s
- 9-16 All dance parallel reels of 4 across set
- 17-24 2s+1s also 4s+3s circle 4H once round to left, set and dance RH across ½ way
- 25-32 2s+4s dance LH across once round, 2s and 4s dance out through sides passing opposite partner RSh and chase round set clockwise to next place. 2341

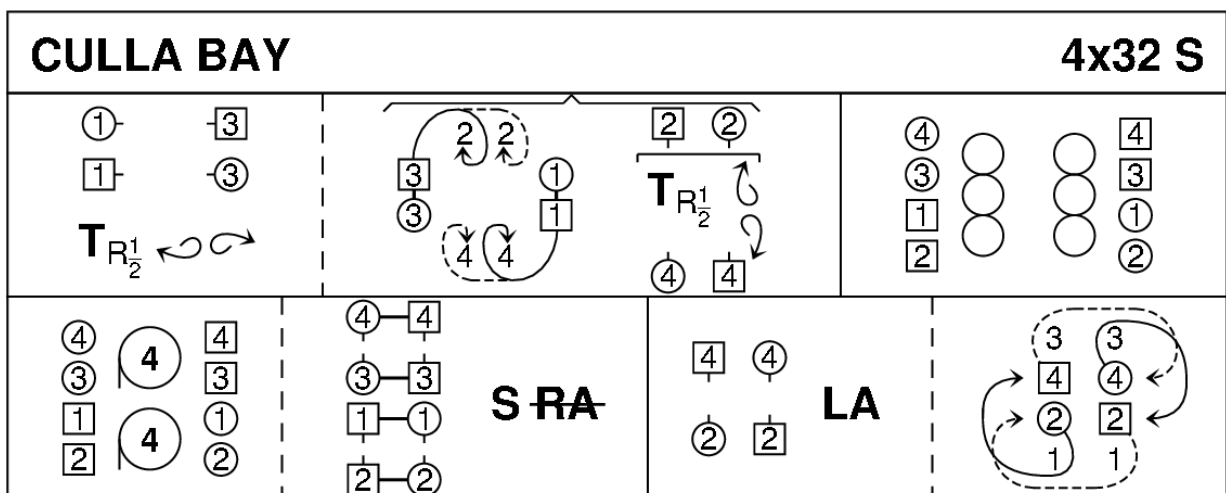

FAREWELL TO BALFOUR ROAD (J1x96) 5C set, Andrew Buxton, Book 52



1- 8 1s+2s circle 4H round and back

9-16 1s+2s Set+Link; 1s+3s Set+Link

17-24 *2s start* while 1s+4s+5s dance mirror reels of 3 on sides (1s in/down to start)

25-32 1s set, cross down RH to 4th pl (4s step up); set, cross down LH to 5th pl (5s step up) 23451

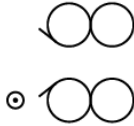
New top couple start every 16 bars. Repeat until 1s back in 1st place, they stand for 16 bars while 5s continue bars 17-32 ending back in 5th place

FAREWELL TO BALFOUR ROAD					
5 couples, 2C start on bar 17					96 J
1 2	1 2	1 3	1 4 5		1x
	S & LINK	S & LINK		S 	S 

GOTHENBURG'S WELCOME (J8x32) Bobby Munro, Book 37

1- 4 1s cast 1 place and set advancing to 1st corner

5-16 1s Dance to Each Corner and Set:-

' 5- 6 1s change places with 1st corners passing RSh and 1st corners pass RSh with a ¼ turn to right in centre to face 2nd corners (as 2nd corners set),

...

Repeat this Fig until 1s end in centre facing 3rd corner positions with 3s and 2s in 1st and 3rd places opposite sides

17-24 1s dance ½ diag Reel of 4 with 3rd corner, pass RSh and dance ½ diag Reel with 4th corners

25-32 1s dance RH hands across (L with 2s and M with 3s) and 2s+1s+3s turn RH

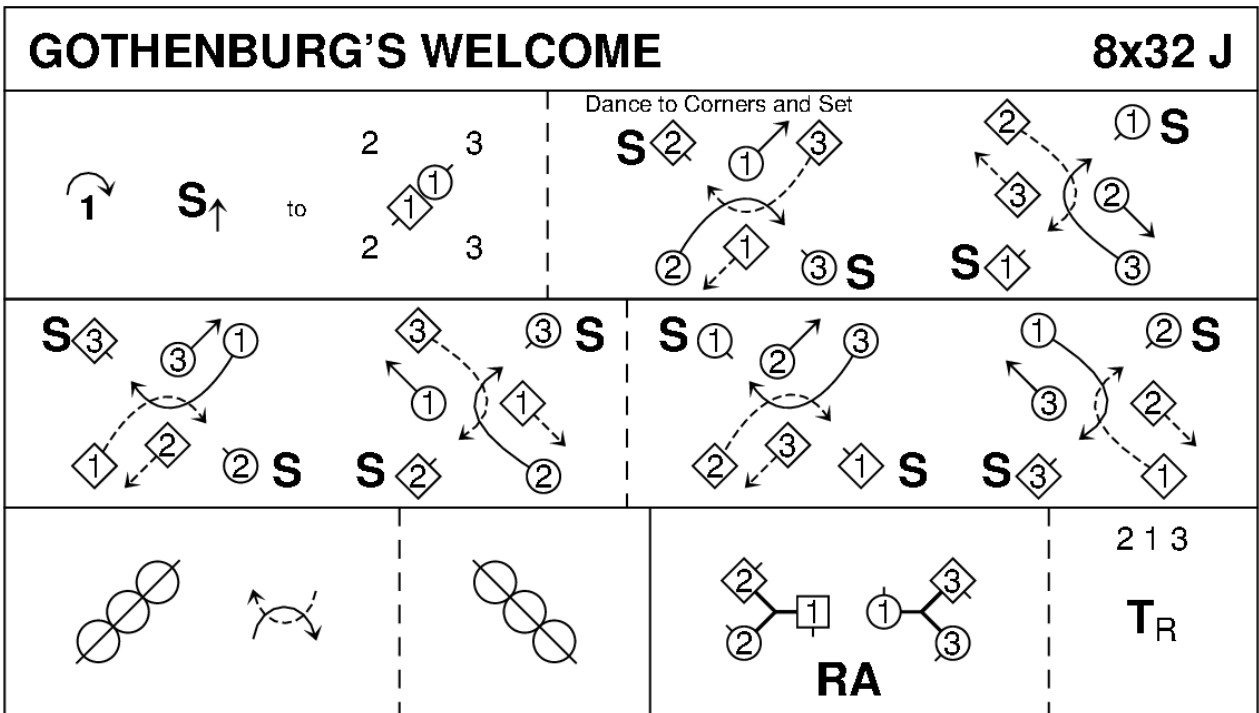

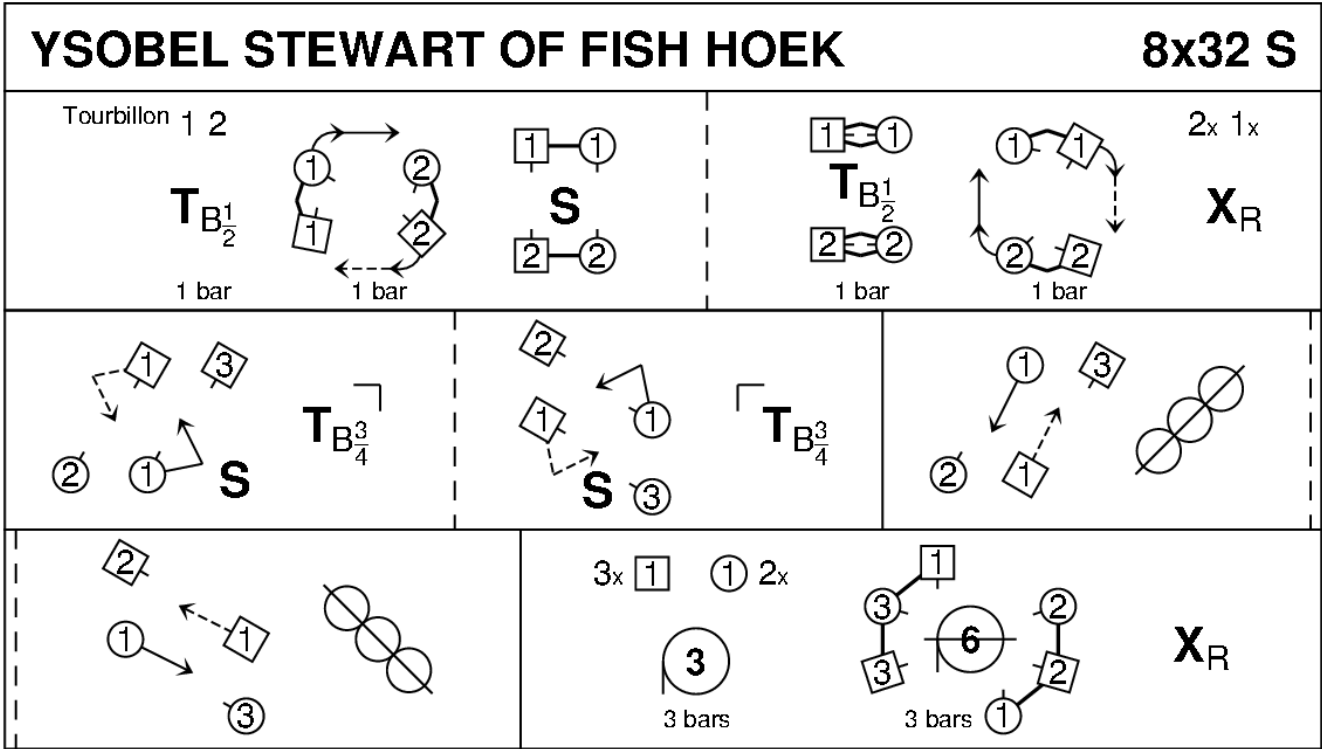

YSOBEL STEWART OF FISH HOEK (S8x32) Mervyn C Short, Book 52

- 1- 8 1s+2s dance the Tourbillon
- 9-12 1s set advancing to 1st corners and turn corners 2H into lines of 3 across, 1L between 2s, 1M between 3s
- 13-16 1s set advancing to 2nd corners and turn corners 2H to end 1s in 2nd place opposite sides
- 17-24 1s pass LSh to dance ½ diag reel of 4 with 3rd corners, pass LSh to dance ½ diag reel of 4 with 4th corners. 1s end in 2nd place own sides
- 25-30 1L+3s (at top) and 1M with 2s (at bottom) dance 3H round to Left, 1s drop LH and 1L leads 3s down Ladies' side, 1M leads 2s up Men's side into circle 6H ½ round to Left. 2(1)3
- 31-32 1s cross RH to own sides



REEL OF THE 51ST DIVISION (R8x32) Atkinson, Book 13

- 1- 8 1s Set&Cast below 3s, lead up to face 1st corners
- 9-16 1s set and turn 1st corners RH to balance in diagonal line, set and 1s turn LH to face 2nd corners
- 17-24 1s set and turn 2nd corners RH to Balance-in-Line, set and 1s turn LH to 2nd place own sides
- 25-32 2s+1s+3s circle 6H round and back

THE REEL OF THE 51st DIVISION			8x32 R
S  	S [⌈] T _R B [⌈] T _L ^{1/4}	[⌈] S [⌈] T _R [⌈] B [⌈] T _L	2 1 3 