

Vom selben Team, das auch Kloster Dance 2019 produziert hat!



Liebe Tänzer/innen!

Wir laden Euch recht herzlich ein zu unserem Tanzabend

Kloster Dance 2020

am 28. März 2020 um 19 Uhr

im evgl. Gemeindezentrum

in Duisburg-Huckingen, Angerhauser Str. 91, 47259 Duisburg

**Neue
Location!**

≈≈≈

Programm

A Wee Nothin'
Follow Your Dreams
The Swans of Atlanta

Davy Nick Nack
Anna's Wedding Cake
Morland Reel

McPherson's Jig
The Expert Dancer
The Reel of the Royal Scots

City of Stirling
From Finland to Bavaria
A Secret Rendezvous

The Piper and the Penguin
Sylvia Full of Grace
Wild Geese

Wherever You Maybe
The Parting Kiss
The Yellow Fliers

Das Programm und alle anderen Details findet Ihr demnächst auch auf unserer Seite www.swinging-kilts.de. All denen, die in unserem Email-Verteiler sind, schicken wir es sowieso zu. (Schickt eine Mail an storkthomas@aol.com, wenn Ihr bisher noch nicht in unserem Verteiler seid.)

Unser Tanzabend findet diesmal woanders statt:

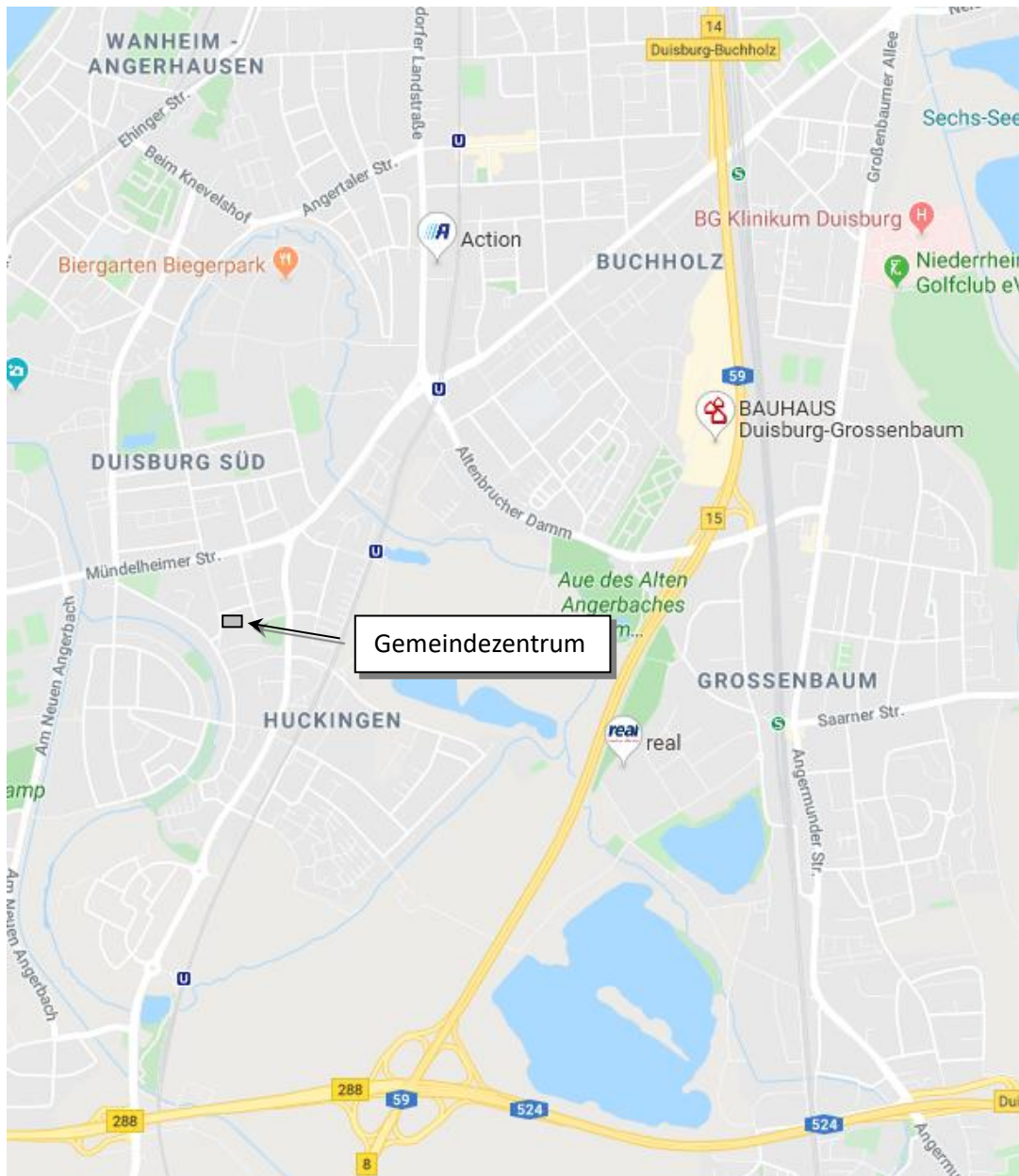

(Wegbeschreibung und besseres Bild demnächst auf unserer Webseite.)

Happy Dancing wünschen









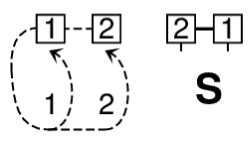
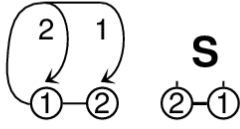

The Swinging Kilts

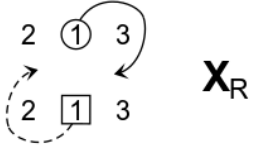
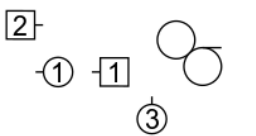

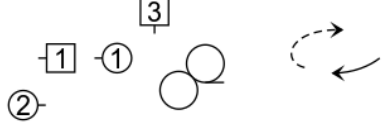
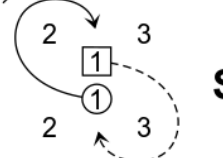
KlosterDance 2020



A Wee Nothin'	J 8x32	L
Follow Your Dreams	R 8x32	M
Swans of Atlanta	M 32	L
Davy Nick Nack	R 8x32	L
Anna's Wedding Cake	S 3x32	L
Morland Reel	J 8x32	M
MacPherson's Jig	J 3x32	S
The Expert Dancer	S 8x32	M
Reel of the Royal Scots	R 8x32	M
Piper and Penguin	R 88	L
From Finland to Bavaria	J 8x32	S
A Secret Rendezvous	S 8x24	M
City of Stirling Reel	R 8x32	M
Sylvia Full of Grace	S 3x32	L
Wild Geese	J 8x32	L
Wherever You Maybe	J 8x32	M
The Parting Kiss	S 3x32	M
The Yellow Fliers	R 3x32	M



KlosterDance 2020

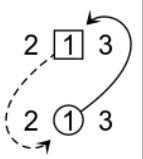
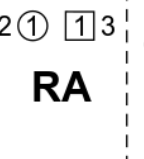
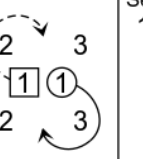
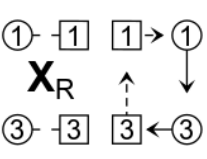

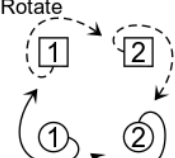
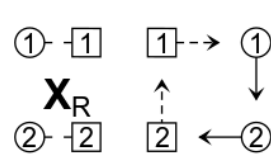
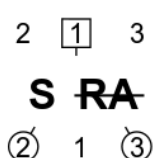
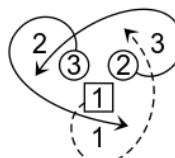
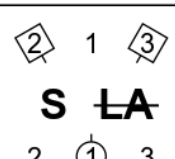
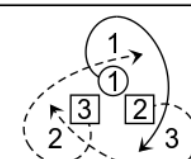

A WEE NOTHIN'				8x32 J
1 2 RA	1 2 LA	 S	 S	2 1 RL
FOLLOW YOUR DREAMS				8x32 R
S 	 X_R	 S X_R	 S X_R	
 S X_R	 S X_R	 S X_R		
THE SWANS OF ATLANTA				4x32 (S+R)
8	— Ladies — RA  S clockw. to new partner 1 pos	— Men — LA  S anticw. to new partner 1 pos	1M 3M T_{R1/2} T_{wirl} to opp. places	2M 4M T_{R1/2} T_{wirl} to opp. places

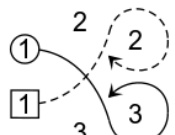
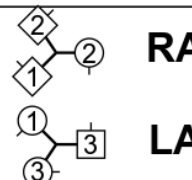

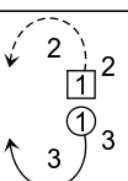
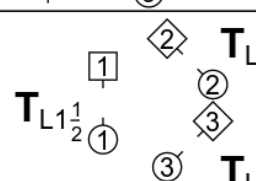
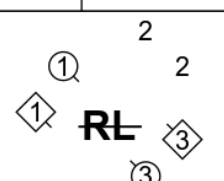
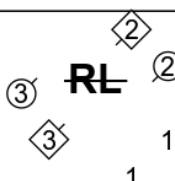
Catherine Shaw, 2016, RSCDS Atlanta, Celeb. 40 Y. of Dancing Mem. 4C/4C square set

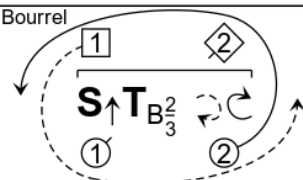
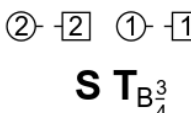
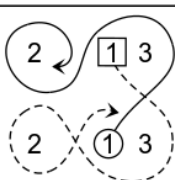
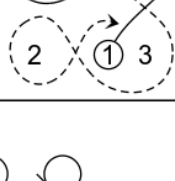
DAVY NICK NACK				8x32 R	
1 2 3 X_R S	1x 2x 3x X_R S	T_{R1/2}  T_L	T_{R1/2} S T_{R1/2} T_L	R	
ANNA'S WEDDING CAKE				3x32 S	
T_B 	 RA	 RA	Set and Rotate 1 3 S 	 X_R	2 3 1 6

THE MORLAND REEL		8x32 J	
Set and Rotate 1 2  <p>S</p>	 <p>X_R</p>	2 1 3  <p>S RA</p>	
 <p>S LA</p>		2 1 3 	

MACPHERSON'S JIG		3x32 J	
	 <p>RA LA</p>		
	 <p>T_L T_L</p>	 <p>RL</p>	 <p>RL</p>

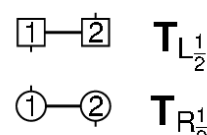
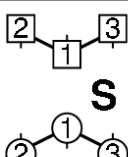
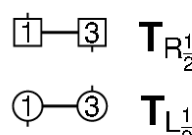
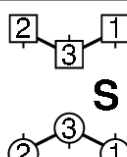
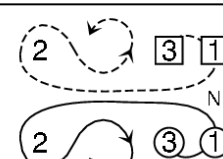
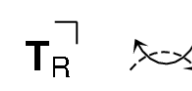
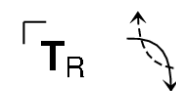
THE EXPERT DANCER		8x32 S	
Bourrel  <p>S T_B</p>	 <p>S T_B</p>		
			

THE REEL OF THE ROYAL SCOTS		8x32 R	
 <p>T_L</p>	 <p>S</p>	 <p>T_R</p>	 <p>S</p>
	 <p>T_R</p>	 <p>T_R</p>	2 1 3 

THE PIPER AND THE PENGUIN						88 R		
	RA		LA		RA		LA	
1 3 T_{R1 1/4}		1 3 RL	2 4 R 16 bars					Chase
				ALL T_{R1 1/4}	PROM anticlockwise			

FROM FINLAND TO BAVARIA				8x32 J	
Bourrel 				Change lead at ends of reel 	
				2 1 3 6	

Ute Hoppmann-Lacour, 2017, High Time 3C/4C longwise set.

A SECRET RENDEZVOUS				8x24 S	
1 2 partner S RL T_{R3/4}		prtnr T_R		prtnr T_R	Highland Schottische Poussette

Iain Boyd, 1991, May I have the Pleasure? 2C/4C longwise set

CITY OF STIRLING REEL						8x32 R	
Snowball Chain 							

SYLVIA FULL OF GRACE 3x32 S

$\overbrace{\quad\quad\quad}^{2 \quad 1 \quad 3}$ $T_R T_L$ CHASE clockwise	$\begin{matrix} 1 & 2 \\ A \end{matrix}$		$\begin{matrix} 1 & 3 \\ KNOT \end{matrix}$
---	--	--	---

Marshall+Anne McLaughlin, Spring Creek Collection. 3C longwise set

THE WILD GEESE 8x32 J

$\begin{matrix} 1 & 3 \\ S \uparrow \\ S \end{matrix}$	$\begin{matrix} 1 & 3 \\ T_{R\frac{3}{4}} \\ \text{Diagram} $	$\begin{matrix} 3 & 1 \\ R \end{matrix}$	$\begin{matrix} \rightarrow \\ \leftarrow \\ R \\ \text{to 2nd place} \end{matrix}$	$\begin{matrix} 2 & 1 \\ RL \end{matrix}$
--	---	--	---	---

WHEREVER YOU MAYBE 8x32 J

$T_{R\frac{3}{4}}$ to $\begin{matrix} - & 1 & 2 & M & - \\ S & RA \end{matrix}$		$T_{R\frac{3}{4}}$ to $\begin{matrix} - & 1 & 2 & L & - \\ S & RA \end{matrix}$ (6)
---	--	---

Iain Boyd, 2010, May I Have the Pleasure? 3C/4C longwise set

THE PARTING KISS 3x32 S

$\begin{matrix} \text{---} & 1 & 2 & \text{---} \\ T_{R\frac{3}{4}} & \text{Diagram} & T_{R\frac{3}{4}} \\ \text{Half Reel Progression} \end{matrix}$	(6)	$\begin{matrix} \text{---} & 2 & 1 & 3 & \text{---} \\ S & S & \text{Diagram} & \text{Diagram} \\ \text{Set \& Shutt} \end{matrix}$	$\begin{matrix} 2 & 1 & 3 \\ S & T_{R\frac{1}{2}} & A \end{matrix}$
---	-----	---	---

Iain Boyd, 1998, May I have the Pleasure? 3C/3C longwise set

THE YELLOW FLIERS 8x32 J

X_R	$\begin{matrix} 2 & 1 & 3 \\ \updownarrow \end{matrix}$	$\begin{matrix} \text{ALL} \\ X_R \end{matrix}$ $\begin{matrix} 2 & 3 \\ S \\ \text{pivoting} \end{matrix}$	
	$\begin{matrix} \text{ALL} \\ X_R \end{matrix}$ $\begin{matrix} 3 & 2 \\ S \\ \text{pivoting} \end{matrix}$	$\begin{matrix} 3 & 1 & 2 \\ \text{RL} & 2 & \end{matrix}$	$\begin{matrix} 3 & 1 & 3 \\ \text{RL} & 2 & \end{matrix}$

R.Allen, 2016, Celebrating 40 Years of Dancing Memories 3C/4C longwise set